

MINUTES OF THE REGULAR MEETING
OF THE BOARD OF COMMISSIONERS OF
GALVESTON COUNTY EMERGENCY SERVICES DISTRICT NO. 2

A regular meeting of the Board of Commissioners of Galveston County Emergency Services District No. 2 (the “District”) was called for at 12:00 p.m. on October 16, 2024 at the Crystal Beach fire station, 930 Noble Carl Road, Crystal Beach, Texas 77650, pursuant to notice duly posted according to law.

The regular was called to order at approximately 12:00 p.m., and the roll was called of the duly constituted officers and members of the Board, to wit:

Kate Newberry	President
Tim Byrom	Vice President
Cecil Clay	Secretary
Greg Fountain	Treasurer
Tim Hardy	Assistant Treasurer

All of said Board members were present, thus constituting a quorum. Also present at the regular meeting were: Doug Saunders, District Manager; Georgia Osten, District Administrative Assistant; MaKayla Vidal, the District’s accountant; Joshua Heinz of Benckenstein & Oxford, LLP, attorney for the District (Mr. Heinz attended via conference call); and, the individuals listed on the sign-in sheet attached hereto as **Exhibit A**.

Upon establishing that a quorum was present, the Board members and others in attendance said the U.S. and Texas pledges of allegiance.

President Newberry then directed the Board to Agenda Item No. 4 for public comment, at which time Leanne Comeaux advised that Port Bolivar VFD desires to place location markers on the North Jetty for emergency service response purposes, but will consult with state and local authorities prior to placing any location markers. Mr. Saunders then also advised that Galveston County will be placing a sign at the entrance of the North Jetty advising of various dangers.

The Board then moved along to Agenda Item No. 5, at which time Vice President Byrom made a motion to approve and authorize the following matters listed under the consent agenda, which was seconded by Assistant Treasurer Hardy and unanimously approved by the Board:

- a. Minutes of the September 18, 2024 Public Hearing and Regular Meeting;
- b. Payment of District Bills and Accounts (**Exhibit B**)¹; and,
- c. VFDs' Monthly Expense Reimbursements (**Exhibit C**)².

The Board was then directed to Agenda Item No. 7, at which time Treasurer Fountain reviewed the financial information contained in the meeting packet, including the regular monthly Treasurer's Report, which is attached hereto as **Exhibit D**³, along with the District's Quarterly Investment Report, which is attached hereto as **Exhibit E**. Upon motion by Assistant Treasurer Hardy and seconded by Vice President Byrom, the Board members unanimously approved the Quarterly Investment Report. The Board also reviewed the following proposed FY 2023-24 budget amendments: ESD-001, Capital-001, EMS-001, and HIVFD-002, copies of which are attached hereto as **Exhibit F**. Upon motion by Assistant Treasurer Hardy and seconded by Treasurer Fountain, the foregoing FY 2023-24 budget amendments were unanimously approved.

Then, under Agenda Item No. 7, Mr. Saunders reviewed with the Board the quotes received for the proposed purchase of Radios (Motorola - \$34,860.00 and \$502.83), UE Scopes (Bound Tree - \$10,604.54), and Stretcher / Powered Stair Chair (Stryker - \$52,380.02), copies of which are attached hereto as **Exhibit G**. Upon motion by Treasurer Fountain and seconded by

¹ Check Nos. 4038-4060 and 4062-4075, plus the EFT payments and direct deposit/payroll expenses. It was also noted that Check No. 4061 had been voided.

² Port Bolivar VFD - \$11,868.54 (September 2024); High Island VFD - \$3,563.37 (September 2024); and, Crystal Beach VFD - \$1,640.15 (September 2024).

³ Texas First Bank operating checking account (xx6680) - \$199,588.16 as of 9/30/2024 and \$282,183.17 as of 10/16/2024; Texas First Bank savings account (xx9804) - \$2,529.80 as of 9/30/2024 and 10/16/2024; Texas First Bank EMS billing checking account (xx7569) - \$151,277.78 as of 9/30/2024 and \$154,904.96 as of 10/16/2024; TexSTAR investment pool general fund account (xxxxxx1110) - \$1,559,717.66 as of 9/30/2024 and 10/16/2024;

Vice President Byrom, the Board members unanimously approved the proposed equipment purchases. Mr. Saunders also advised that High Island VFD had provided notice of its intent to purchase, with its own funds, a 500-gallon fuel tank to be placed at the High Island fire station (*see* **Exhibit H** attached hereto).

Next, the Board was directed to Agenda Item No. 8, at which time Mr. Saunders reviewed with the Board the updated job descriptions for the EMS Supervisor and EMT/Paramedic positions, copies of which are attached hereto as **Exhibit I**. Upon motion by Vice President Byrom and seconded by Treasurer Fountain, the Board members unanimously approved the updated EMS Supervisor and EMT/Paramedic job descriptions.

The Board then moved ahead to Agenda Item No. 10, at which time Mr. Saunders recommended that the Polaris ATV described on **Exhibit J** attached hereto be declared as surplus property and either donated to Port Bolivar VFD, or, if Port Bolivar VFD does not want said unit, that it be sold through Purple Wave online auction. Mr. Saunders also recommended that the items described on **Exhibit K** attached hereto be declared as salvage property and disposed of. Upon motion by Assistant Treasurer Hardy and seconded by Treasurer Fountain, the Board unanimously declared the Polaris ATV as surplus property and approved donation of same to Port Bolivar VFD, or, if Port Bolivar VFD declines the donation, sale of the unit through Purple Wave online auction; and, declared the other listed items as salvage property and authorized Mr. Saunders to dispose of same in the manner he deems appropriate.

Thereafter, the Board was directed to Agenda Item No. 11, at which time Mr. Saunders reviewed with the Board his monthly Manager's Report, a copy of which is attached hereto as **Exhibit L**.

TexSTAR investment pool capital fund account (xxxxxx1890) - \$132,413.16 as of 9/30/2024 and 10/16/2024; and, TexSTAR investment pool emergency fund account (xxxxxx4140) - \$1,133,602.46 as of 9/30/2024 and 10/16/2024.

Being as there were no matters to come before the Board under Agenda Item No. 12, the Board moved along to Agenda Item No. 13, at which time Mrs. Vidal reviewed with the members the various District financial reports, copies of which are attached hereto as **Exhibit M**.

Being as there were no other matters to come before the Board under Agenda Item No. 14, the regular meeting was adjourned at approximately 1:24 p.m.

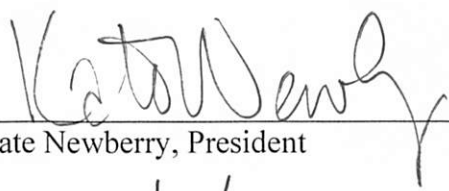

Kate Newberry, President
Date: 11 / 20 / 2024

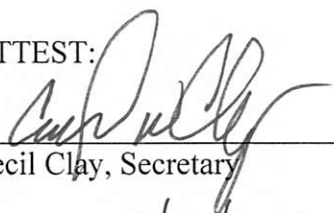
ATTEST:

Cecil Clay, Secretary
Date: 11 / 20 / 2024

Exhibit A

Exhibit B

Galveston County Emergency Services No. 2

Check Detail

September 19 - October 17, 2024

DATE	TRANSACTION TYPE	NUM	NAME	MEMO/DESCRIPTION	CLR	AMOUNT
6680	Checking Texas First					
10/16/2024	Check	4038	Vidal Accounting, PLLC	Inv. 00071		-1,925.00 1,925.00
10/16/2024	Check	4039	Joshua C. Heinz	Atty. Fees - Sept. '24		-1,000.00 1,000.00
10/16/2024	Check	4040	Galveston County Tax Office	GC Daily News Inv. 56336		-684.65 684.65
10/16/2024	Check	4041	Cyber One Solutions	Inv. 72635		-257.10 257.10
10/16/2024	Check	4042	Unlted Data Technologies, Inc.	Inv. 5092024099		-330.00 330.00
10/16/2024	Check	4043	East Texas GC Regional Trauma Advisory	Inv. M2024		-250.00 250.00
10/16/2024	Check	4044	Summit Fire & Security	Inv. 2525699		-698.21 698.21
10/16/2024	Check	4045	Winnie Dodge	inv. 31893		-76.50 76.50
10/16/2024	Check	4046	Priority Public Safety	Inv. 1383		-635.00 635.00
10/16/2024	Check	4047	Stericycle	Cust. 3000924273, Inv. 8008507947		-224.25 224.25
10/16/2024	Check	4048	Sparklets & Sierra Springs	Inv. 23216915		-136.86 136.86
10/16/2024	Check	4049	Baptist Health Training Center	44500		-90.00 90.00
10/16/2024	Check	4050	Teleflex LLC	Inv. 9508933185		-395.50 395.50
10/16/2024	Check	4051	Deluxe	Cust.604999722, Inv. 9005922752		-426.81 426.81
10/16/2024	Check	4052	AT&T Mobillty	287327593524, inv. 287327593524		-210.66 210.66
10/16/2024	Check	4053	Magnum Electronics, Inc.	Inv. 2024/12968		-214.39 214.39
10/16/2024	Check	4054	Stallon Automation, Inc dba PSTrax	Inv. 6695		-3,275.00 3,275.00
10/16/2024	Check	4055	Christopher's Speedy Lube	Invoice 90428		-110.00 110.00
10/16/2024	Check	4056	Frazer	Inv. 97099		-304.68 304.68
10/16/2024	Check	4057	Acid Remap LLC	Protocol App Inv. 2214		-750.00 750.00
10/16/2024	Check	4058	High Island VFD	September '24 Reimbursement		-3,563.37 3,563.37
10/16/2024	Check	4059	Crystal Beach VFD	September '24 Reimbursement		-1,640.15 1,640.15
10/16/2024	Check	4060	Port Bolivar VFD	September '24 Reimbursement		- 11,868.54 11,868.54

Galveston County Emergency Services No. 2

Check Detail
September 19 - October 17, 2024

DATE	TRANSACTION TYPE	NUM	NAME	MEMO/DESCRIPTION	CLR	AMOUNT
10/16/2024	Check	4062	Pete Jorgensen Marine	Doc No. 46064		-465.92 465.92
10/16/2024	Check	4063	D and H Bolivar Rentals, LLC	Oct., Nov., Dec. 2024 Rent - Choctaw		-3,525.00 3,525.00
10/16/2024	Check	4064	VFIS	Inv. 15403 - Karavan Trailer		-82.48 82.48
10/16/2024	Check	4065	Visa	Office Depot,HP,Amazon Direct TV Frontier Waste		-736.60 222.36 216.74 297.50
10/16/2024	Check	4066	Visa	Adobe,Intult,Foxit Amazon AT&T Amazon,HP,Sams,UPS,Savvy Trendz Amazon Galls,Nova Biomedical		-4,190.75 500.00 1,000.00 300.00 644.90 545.85 1,200.00
10/11/2024	Check	4067	GCM, The Big Store	575 458,952,836		-346.98 33.56 313.42
10/16/2024	Check	4068	Impact EMS	Inv. INVENT197		-6,331.00 6,331.00
10/16/2024	Check	4069	HdL Companles	Inv. SIN043628		-3,600.00 3,600.00
10/16/2024	Check	4070	Baptist Health Training Center	Inv. 5441		-90.00 90.00
10/16/2024	Check	4071	Municipal Emergency Services	MES - Inv. IN2130628 MES - Inv. IN2130628 MES - Inv. IN2130628		-1,554.18 518.06 518.06 518.06
10/16/2024	Check	4072	O'Reilly Automotive, Inc.	5882-426594,426864,427757,483138		-457.23 457.23
10/16/2024	Check	4073	Coastal Welding	0080302617,0010789980		-471.86 471.86
10/16/2024	Check	4074	Benckenstein & Oxford	Inv. 51158		-1,042.00 1,042.00
10/16/2024	Check	4075	Bound Tree	Inv.85521788,9076,0331,2425,2426,3895,0951,7234		-2,985.44 2,985.44
09/20/2024	Expense			ADP PAYROLL FEES/ADP FEES 430061 ADP PAYROLL FEES/ADP FEES XXXXXXXX6616 670757240GALVES ADP PAYROLL FEES/ADP FEES 430061 ADP PAYROLL FEES/ADP FEES XXXXXXXX6616 670757240GALVES	R	-263.02 263.02
09/27/2024	Expense			ADP PAYROLL FEES/ADP FEES 928234 ADP PAYROLL FEES/ADP FEES XXXXXXXX7689 671194446GALVES ADP PAYROLL FEES/ADP FEES 928234 ADP PAYROLL FEES/ADP FEES XXXXXXXX7689 671194446GALVES	R	-175.00 175.00
09/26/2024	Expense			ADP WAGE GARN/WAGE GARN 78307327 ADP WAGE GARN/WAGE GARN XXXXXXXX7804OFX GALVESTON COUN ADP WAGE GARN/WAGE GARN 78307327 ADP WAGE GARN/WAGE GARN XXXXXXXX7804OFX GALVESTON COUN	R	-1,010.80 1,010.80
09/30/2024	Expense			HEALTH CARE SERV/OBPPAYMT 069220 HEALTH CARE SERV/OBPPAYMT XXXXXX7209 PENINSULA EMERGEN HEALTH CARE SERV/OBPPAYMT 069220 HEALTH CARE SERV/OBPPAYMT XXXXXX7209 PENINSULA EMERGEN	R	15,025.95 15,025.95

Galveston County Emergency Services No. 2

Check Detail

September 19 - October 17, 2024

DATE	TRANSACTION TYPE	NUM NAME	MEMO/DESCRIPTION	CLR	AMOUNT
09/30/2024	Expense		SOUTHERN BROADBA/PURCHASE 409 68 SOUTHERN BROADBA/PURCHASE 409 684 7021 Galveston Count	R	-89.00
			SOUTHERN BROADBA/PURCHASE 409 68 SOUTHERN BROADBA/PURCHASE 409 684 7021 Galveston Count		89.00
09/26/2024	Expense		BENE:ADP CLIENT TRUST TRN:P20240 BENE:ADP CLIENT TRUST TRN:PXXXXXXXXX0028561	R	-
			BENE:ADP CLIENT TRUST TRN:P20240 BENE:ADP CLIENT TRUST TRN:PXXXXXXXXX0028561		24,325.24
09/25/2024	Expense		DSHS Reg Prog/Lic Fee 537RG14761 DSHS Reg Prog/Lic Fee 537RG1476119PRD GCEDS2	R	-1,590.00
			DSHS Reg Prog/Lic Fee 537RG14761 DSHS Reg Prog/Lic Fee 537RG1476119PRD GCEDS2		1,590.00
09/25/2024	Expense		BENE:ADP CLIENT TRUST TRN:P20240 BENE:ADP CLIENT TRUST TRN:PXXXXXXXXX0024739	R	-
			BENE:ADP CLIENT TRUST TRN:P20240 BENE:ADP CLIENT TRUST TRN:PXXXXXXXXX0024739		66,361.36
09/24/2024	Expense	Undine	Undine Bolivar P/ECHK081681 GCES Undine Bolivar P/ECHK081681 GCESD2 3	R	-111.10
			Undine Bolivar P/ECHK081681 GCES Undine Bolivar P/ECHK081681 GCESD2 3		111.10
10/04/2024	Expense		ADP PAYROLL FEES/ADP FEES 927635 ADP PAYROLL FEES/ADP FEES XXXXXXXX0713 671863394GALVES	C	-255.78
			ADP PAYROLL FEES/ADP FEES 927635 ADP PAYROLL FEES/ADP FEES XXXXXXXX0713 671863394GALVES		255.78
10/10/2024	Expense	Galveston County Auditor	Bol Pen SUD/DIRECT PAY GALVESTON Bol Pen SUD/DIRECT PAY GALVESTON COUNTY ESD2	C	-180.60
			Bol Pen SUD/DIRECT PAY GALVESTON Bol Pen SUD/DIRECT PAY GALVESTON COUNTY ESD2		180.60
10/10/2024	Expense	Galveston County Auditor	Bol Pen SUD/DIRECT PAY GALVESTON Bol Pen SUD/DIRECT PAY GALVESTON COUNTY ESD2	C	-277.64
			Bol Pen SUD/DIRECT PAY GALVESTON Bol Pen SUD/DIRECT PAY GALVESTON COUNTY ESD2		277.64
10/10/2024	Expense		ADP WAGE GARN/WAGE GARN 47257330 ADP WAGE GARN/WAGE GARN XXXXXXXX1085OFX GALVESTON COUN	C	-1,010.80
			ADP WAGE GARN/WAGE GARN 47257330 ADP WAGE GARN/WAGE GARN XXXXXXXX1085OFX GALVESTON COUN		1,010.80
10/11/2024	Expense		COLONIAL LIFE/INS. PREM. E540746 COLONIAL LIFE/INS. PREM. E5407465 GALVESTON COUNTY ESD	C	-857.24
			COLONIAL LIFE/INS. PREM. E540746 COLONIAL LIFE/INS. PREM. E5407465 GALVESTON COUNTY ESD		857.24

Exhibit C



Port Bolivar Volunteer Fire Department

PO Box 675 Port Bolivar, Texas 77650 1806 Broadway
 Ph: 409-684-1984 Fax: 409-684-1003 pbvfd@att.net

Date: 09/30/2024.

Attention: ESD 2 Board

Port Bolivar Volunteer Fire Department is requesting from the ESD #2 Board Reimbursement for our September 2024 bills totaling \$11,868.54.

Company	Description	Cost	Paid By	Code
AT&T	Internet/Phone	\$179.03 ✓	CK #1424	2820
AT&T Mobility	Internet/Phone FirstNet	\$42.00 ✓	CK #1425	2820
Entergy	Inside Lights	\$376.22 ✓	CK #1428	2830
Entergy	Outside Lights	\$98.67 ✓	CK #1429	2830
Frontier Waste BAYOU	Trash	\$252.50 ✓	CK #1423	2840
BeenVerified	Background Checks	\$31.78	Credit Card	4610
John Williams Reimbursement from Sam's Club	Forever Stamps	\$145.50 ✓	CK #1427	2310
Amazon.com	Oil Filters and Spark Plug Tune up kit	\$45.38 ✓	Credit Card	4000

Amazon.com	Office Supplies: Label Tape, Post- It, file folders, and Scotch table	\$71.67 ✓	Credit Card	2310
Gulf Coast Market (The Big Store)	Ext Cords	\$85.95 ✓	Credit Card	4000
Gulf Coast Market (The Big Store)	Hose, Degreaser, and Nozzle	\$100.77 ✓	Credit Card	4000
Gulf Coast Market (The Big Store)	Motor Oil	\$69.90 ✓	Debit Card	4000
Zoom.US	Zoom Software	\$149.90 ✓	Credit Card	2110
American Technology Network, Corp	Compact Thermal Monocular	\$2,895.00 ✓	Credit Card	4000
Positive Promotions	Fire Prevention	\$1,750.00 ✓	Credit Card	2550
BearCom	Radio Knobs	\$134.83 ✓	CK #1426	4350
Amazon	Fuel Filter and Air Filter for Brush Truck Pump Engines	\$39.44 ✓	Credit Card	4000
Manhattan Life Insurance and Annuity Company	Supplemental Health Insurance	\$5,400.00 ✓	CK #5871	2410



Port Bolivar Volunteer Fire Department

PO Box 675 Port Bolivar, Texas 77650 1806 Broadway
Ph: 409-684-1984 Fax: 409-684-1003 pbvfd@att.net

Certification of Expense Request FY 2023-2024

Acting in my capacity as Treasurer, on behalf of the **Port Bolivar Volunteer Fire Department**, we certify that the following expense reimbursement request of \$11,868.54 for the month of September 2024 bills are true and correct to the best of our knowledge and have been procured in accordance with state and federal guidelines governing expenditures of public funds and have been authorized for submission to the Galveston County Emergency Services District #2 by the **Port Bolivar Volunteer Fire Department Board of Directors**.

Printed Name: John B. Williams, Treasurer

Signature: _____

Date: _____

10/05/2024

Printed Name: William Weeks, President

Signature: _____

Date: _____

10-5-24

PORT BOLIVAR VFD 2023-2024

September '24

Revised 8.21.24

	BUDGET	Prior	Current	Total	Remaining
	2023-24	Month	Month		Budget
		Total	September '24		
2000 - Auditing Fees				\$ -	\$ -
2010 - Accountant Fees	\$ 1,200.00	\$ 1,150.00		\$ 1,150.00	\$ 50.00
2100 - Bookkeeping	\$ 500.00	\$ 238.77		\$ 238.77	\$ 261.23
2110 - Software Services	\$ 1,250.00	\$ 783.49	\$ 149.90	\$ 933.39	\$ 316.61
2200 - Legal Fees				\$ -	\$ -
2210 - Professional Fees Other				\$ -	\$ -
2310 - Office Supplies (increase)	\$ 2,000.00	\$ 1,212.22	\$ 217.17	\$ 1,429.39	\$ 570.61
2320 - Office Equipment	\$ 500.00	\$ 499.95		\$ 499.95	\$ 0.05
2340 - Cleaning Supplies (decrease)	\$ -			\$ -	\$ -
2410 - Insurance - Accident & Sickness	\$ 6,500.00	\$ 944.00	\$ 5,400.00	\$ 6,344.00	\$ 156.00
2420 - Insurance - Bldg, Equip, & Gen Liab				\$ -	\$ -
2430 - Insurance - Auto/Boat				\$ -	\$ -
2440 - Insurance Workers Comp				\$ -	\$ -
2450 - Bond				\$ -	\$ -
2500 - Travel Expenses	\$ 650.00			\$ -	\$ 650.00
2510 - Mileage reimbursements/tolls	\$ 1,000.00			\$ -	\$ 1,000.00
2550 - Fire Prevention	\$ 1,750.00		\$ 1,750.00	\$ 1,750.00	\$ -
2700 - Dues & Subscriptions	\$ 900.00	\$ 819.00		\$ 819.00	\$ 81.00
2710 - Safe D				\$ -	\$ -
2720 - License & Permits	\$ 800.00			\$ -	\$ 800.00
2730 - Public Relations				\$ -	\$ -
2740 - Good of the Department				\$ -	\$ -
2750 - Billing Service Fees				\$ -	\$ -
2810 - Bldg Rent				\$ -	\$ -
2820 - Telephone & Com. (increase)	\$ 2,700.00	\$ 2,451.58	\$ 221.03	\$ 2,672.61	\$ 27.39
2830 - Electricity (increase)	\$ 10,500.00	\$ 6,493.07	\$ 474.89	\$ 6,967.96	\$ 3,532.04
2840 - Water/Garbage	\$ 3,300.00	\$ 2,777.50	\$ 252.50	\$ 3,030.00	\$ 270.00
2850 - Propane				\$ -	\$ -
2860 - Janitorial/Yard Service				\$ -	\$ -
2870 - Alarm Services	\$ 1,000.00	\$ 639.99		\$ 639.99	\$ 360.01
2900 - General & Administrative				\$ -	\$ -
3100 - Uncategorized				\$ -	\$ -
4000 - Firefighting/Maint/Repair (decrease)	\$ 12,800.00	\$ 3,788.07	\$ 3,236.44	\$ 7,542.57	\$ 5,257.43
4200 - Fuel	\$ 4,500.00	\$ 3,428.10		\$ 3,428.10	\$ 1,071.90
4210 - Oxygen/Breathing Air	\$ 3,500.00	\$ 3,518.55		\$ 3,518.55	\$ (18.55)
4300 - Radio Usage	\$ 3,500.00	\$ 2,880.00		\$ 2,880.00	\$ 620.00
4350 - Radio Repair	\$ 2,000.00	\$ 1,104.87	\$ 134.83	\$ 1,239.70	\$ 760.30
4400 - General & Administrative				\$ -	\$ -
4500 - Training (decrease)	\$ 6,500.00			\$ -	\$ 6,500.00
4600 - Medical Exams	\$ 500.00			\$ -	\$ 500.00
4610 - Background Checks	\$ 500.00	\$ 315.89	\$ 31.78	\$ 347.67	\$ 152.33
4620 - Recruiting				\$ -	\$ -
4700 - Building Maintenance				\$ -	\$ -
4800 - Uniforms	\$ 1,000.00			\$ -	\$ 1,000.00
4900 - Vehicle Maint. & Repair	\$ 2,500.00	\$ 2,500.00		\$ 2,500.00	\$ -
5000 - Command Vehicle				\$ -	\$ -
5010 - Rescue/Medical				\$ -	\$ -
5020 - Fire Fighting (PPE)				\$ -	\$ -
5030 - Boat				\$ -	\$ -
5040 - Building				\$ -	\$ -
5050 - Other				\$ -	\$ -
	\$ 71,850.00		\$ 11,868.54		\$ 23,918.35



High Island Volunteer Fire Rescue
 P.O. Box 144
 High Island, Texas 77623

INVOICE

DATE OCTOBER 1, 2024
 INVOICE # 2024-09

TO Galveston County ESD #2
 930 Nobel Carl Dr
 Crystal Beach, TX 77650

SALESPERSON	JOB	PAYMENT TERMS	DUE DATE
		Due on receipt	
LINE ITEM	DESCRIPTION	UNIT PRICE	LINE TOTAL
2820	Fastwyre Broadband – EFT – Station phones/fax/internet	273.86 ✓	273.86
2830	Entergy – EFT - Electrical Fire Station	534.70 ✓	808.56
2840	Frontier Waste- Bayou EFT - Dumpster	207.50 ✓	1,016.06
2110	Software Service – QuickBooks - EFT	69.29 ✓	1,085.35
2820	Dish – #3167 - Station Cable –	166.41 ✓	1,251.76
2820	Voxtelesys – Local Phone Service - EFT	13.78 ✓	1,265.54
4800	One24 Apparel – Uniforms (Debit)	784.50 ✓	2,050.04
4200	Galveston Co. Auditor's office. Fleet Fuel #3169 (July)	455.83 ✓	2,505.87
2720	GCTO - #3168 – Tag for Brush 1	7.50 ✓	2,513.37
2100	Dunaway & Willis PC # 3166 Federal Tax Return	1050.00 ✓	3,563.37
TOTAL			3,563.37

Make all checks payable to High Island Volunteer Fire Rescue
 Thank you for your business!

HIGH ISLAND



Volunteer Fire/Rescue

P.O. Box 144, 2041 7th Street
High Island, Texas 77623
Phone (409) 286-5811 Fax (409) 286-5424

October 1, 2024

Galveston County ESD # 2
PO Box 1709
Crystal Beach, Texas 77650

Ref: Certification of expense reimbursement request

I, Terrie Riley, acting in my capacity as Treasurer, on behalf of High Island Volunteer Fire Rescue, Inc. do certify that the expense reimbursement request that is submitted for the amount of \$ 3,563.37 is true and correct to the best of my knowledge and has been processed in accordance with State and Federal guidelines governing expenditures of public funds and has been authorized for submission to the Galveston County ESD # 2 by the High Island Volunteer Fire Rescue Inc. Board of Directors.

Signature

Date

10/01/2024

High Island VFD 2023-2024

September '24

Revised 9.18.24

ACTUAL

**BUDGET
2023-24**

**Prior
Month**

**Current
Month
Sept. '24**

Total

**Remaining
Budget**

	BUDGET 2023-24	Prior Month	Current Month Sept. '24	Total	Remaining Budget
2000 - Auditing Fees				\$ -	\$ -
2010 - Accounting Fees				\$ -	\$ -
2100 - Bookkeeping	\$ 1,100.00		\$ 1,050.00	\$ 1,050.00	\$ 50.00
2110 - Software Services	\$ 1,100.00	\$ 639.60	\$ 69.29	\$ 708.89	\$ 391.11
2200 - Legal Fees				\$ -	\$ -
2210 - Professional Fees Other				\$ -	\$ -
2250 - Medical Director Fees				\$ -	\$ -
2310 - Office Supplies				\$ -	\$ -
2320 - Office Equipment				\$ -	\$ -
2410 - Insurance - Accident & Sickness	\$ 4,000.00	\$ 4,000.00		\$ 4,000.00	\$ -
2420 - Insurance - Bldg, Equip, & Gen Liab				\$ -	\$ -
2430 - Insurance - Auto/Boat				\$ -	\$ -
2440 - Insurance Workers Comp				\$ -	\$ -
2500 - Travel	\$ -			\$ -	\$ -
2510 - Mileage Reimbursement/tolls	\$ -			\$ -	\$ -
2550 - Fire Prevention	\$ 750.00	\$ 728.50		\$ 728.50	\$ 21.50
2700 - Dues & Subscriptions	\$ 450.00	\$ 362.55		\$ 362.55	\$ 87.45
2710 - Safe D				\$ -	\$ -
2720 - License & Permits	\$ 150.00	\$ 131.50	\$ 7.50	\$ 139.00	\$ 11.00
2730 - Public Relations				\$ -	\$ -
2740 - Good of the Department				\$ -	\$ -
2750 - Billing Service Fees				\$ -	\$ -
2810 - Bldg Rent				\$ -	\$ -
2820 - Telephone & Communications	\$ 5,500.00	\$ 4,154.95	\$ 454.05	\$ 4,609.00	\$ 891.00
2830 - Electricity	\$ 6,500.00	\$ 4,208.59	\$ 534.70	\$ 4,743.29	\$ 1,756.71
2840 -Water/Garbage	\$ 2,840.00	\$ 2,075.00	\$ 207.50	\$ 2,282.50	\$ 557.50
2850 - Propane				\$ -	\$ -
2860 - Janitorial/Yard Service				\$ -	\$ -
2870 - Alarm Service				\$ -	\$ -
2900 - General & Administrative				\$ -	\$ -
3100 - Uncategorized				\$ -	\$ -
4000 - Firefighting / EMS Equipment	\$ 32,405.00	\$ 32,270.54		\$ 32,270.54	\$ 134.46
4050 - Equipment Maintenance				\$ -	\$ -
4100 - Equipment Repair				\$ -	\$ -
4200 - Fuel	\$ 4,000.00	\$ 3,709.54	\$ 455.83	\$ 4,165.37	\$ (165.37)
4210 - Oxygen/Breathing Air	\$ 3,000.00			\$ -	\$ 3,000.00
4300 - Radio Usage	\$ 2,200.00	\$ 2,117.75		\$ 2,117.75	\$ 82.25
4350 - Radio Repair	\$ 2,225.00	\$ 2,224.82		\$ 2,224.82	\$ 0.18
4400 - General & Administrative	\$ -			\$ -	\$ -
4500 - Training	\$ -			\$ -	\$ -
4600 - Medical Exams				\$ -	\$ -
4610 - Background Checks	\$ 225.00	\$ 225.00		\$ 225.00	\$ -
4700 - Building Maintenance	\$ 6,275.00	\$ 6,249.18		\$ 6,249.18	\$ 25.82
4800 - Uniforms	\$ 2,000.00	\$ 1,144.04	\$ 784.50	\$ 1,928.54	\$ 71.46
4900 - Vehicle Maint. & Repair	\$ 10,000.00	\$ 9,806.33		\$ 9,806.33	\$ 193.67
5000 - Command Vehicle				\$ -	\$ -
5010 - Rescue/Medical/Fire Appar				\$ -	\$ -
5020 - Fire Fighting				\$ -	\$ -
5030 - Boat (EMS Capital)				\$ -	\$ -
5040 - Building				\$ -	\$ -
5050 - Other				\$ -	\$ -
	\$ 84,720.00		\$ 3,563.37		\$ 7,108.74



INVOICE

Crystal Beach Fire & Rescue
930 Noble Carl Dr.
Crystal Beach, Texas 77650

DATE SEPTEMBER 2024

TO Galveston County ESD #2
930 Noble Carl Dr.
Crystal Beach, TX 77650

SALESPERSON	JOB	PAYMENT TERMS	DUE DATE
		Due on receipt	
LINE ITEM	DESCRIPTION	UNIT PRICE	LINE TOTAL
2110	Quick Books 3months	\$22.05	\$ 66.15 ✓
4610	Klein Investments Background checks		\$ 75.00 ✓
4500	RC Health Services JMills EMT class		\$1499.00 ✓

TOTAL **\$1640.15**

CRYSTAL BEACH VFD 2023-2024

September '24

		<u>ACTUAL</u>			
	BUDGET	Prior Month	Current	Total	Remaining
	2023-24	Month	Month		Budget
			September '24		

2000 - Auditing Fees				\$ -	\$ -
2010 - Accountant Fees				\$ -	\$ -
2100 - Bookkeeping				\$ -	\$ -
2110 - Software Services	\$ 1,100.00		\$ 66.15	\$ 66.15	\$ 1,033.85
2200 - Legal Fees				\$ -	\$ -
2310 - Office Supplies				\$ -	\$ -
2320 - Office Equipment				\$ -	\$ -
2410 - Insurance - Accident & Sickness	\$ 6,500.00	\$ 1,862.00		\$ 1,862.00	\$ 4,638.00
2420 - Insurance - Bldg, Equip, & Gen Liab				\$ -	\$ -
2430 - Insurance - Auto/Boat				\$ -	\$ -
2440 - Insurance Workers Comp				\$ -	\$ -
2500 - Travel	\$ 650.00			\$ -	\$ 650.00
2510 - Mileage reimbursement/tolls	\$ 1,000.00			\$ -	\$ 1,000.00
2550 - Fire Prevention				\$ -	\$ -
2700 - Dues & Subscriptions	\$ 1,500.00			\$ -	\$ 1,500.00
2710 - Safe D				\$ -	\$ -
2720 - License & Permits				\$ -	\$ -
2730 - Public Relations				\$ -	\$ -
2740 - Good of the Department				\$ -	\$ -
2750 - Billing Service Fees				\$ -	\$ -
2810 - Bldg Rent				\$ -	\$ -
2820 - Telephone & Communications				\$ -	\$ -
2830 - Electricity (Final Bill-October)				\$ -	\$ -
2840 -Water/Garbage (Final Bill-October)				\$ -	\$ -
2850 - Propane				\$ -	\$ -
2860 - Janitorial/Yard Service				\$ -	\$ -
2870 - Alarm Service				\$ -	\$ -
2900 - General & Administrative				\$ -	\$ -
4000 - Firefighting/Maint/Repair	\$ 22,500.00	\$ 7,524.37		\$ 7,524.37	\$ 14,975.63
4200 - Fuel				\$ -	\$ -
4210 - Oxygen/Breathing Air	\$ 3,500.00	\$ 1,206.58		\$ 1,206.58	\$ 2,293.42
4300 - Radio Usage	\$ 3,500.00	\$ 2,520.00		\$ 2,520.00	\$ 980.00
4350 - Radio Repair				\$ -	\$ -
4400 - General & Administrative				\$ -	\$ -
4500 - Training	\$ 10,000.00	\$ 4,757.80	\$ 1,499.00	\$ 6,256.80	\$ 3,743.20
4600 - Medical Exams				\$ -	\$ -
4610 - Background Checks	\$ 500.00	\$ 375.00	\$ 75.00	\$ 450.00	\$ 50.00
4700 - Building Maintenance				\$ -	\$ -
4800 - Uniforms	\$ 2,500.00			\$ -	\$ 2,500.00
4900 - Vehicle Maint. & Repair	\$ 5,000.00	\$ 940.00		\$ 940.00	\$ 4,060.00
5000 - Command Vehicle				\$ -	\$ -
5010 - Rescue/Medical/Fire Appar				\$ -	\$ -
5020 - Fire Fighting				\$ -	\$ -
5030 - Boat				\$ -	\$ -
5040 - Building				\$ -	\$ -
5050 - ESD-Owned Fire Truck				\$ -	\$ -
	<u>\$ 58,250.00</u>		<u>\$ 1,640.15</u>		<u>\$ 37,424.10</u>

Exhibit D

Galveston County Emergency Services District No. 2
16-Oct-24

	9/30/2024	10/16/2024
	Balance	Balance
Texas First Bank		
Operating/Checking (xxxx6680)	\$ 199,588.16	\$ 282,183.17
Savings (Acct. No. xxx9804)	\$ 2,529.80	\$ 2,529.80
EMS Billing (Acct. No. xxxx7569)	\$ 151,277.78	\$ 154,904.96
	\$353,395.74	\$439,617.93
TexSTAR (Investment Co-Op)		
General Fund (Acct. No. xxxxxx1110)	\$1,559,717.66	\$1,559,717.66
Capital Fund (Acct. No. xxxxxx1890)	\$132,413.16	\$132,413.16
Emergency Fund (Acct. No. xxxxxx4140)	\$1,133,602.46	\$1,133,602.46
	\$2,825,733.28	\$2,825,733.28
TOTALS	\$3,179,129.02	\$3,265,351.21

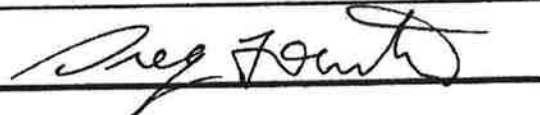

Treasurer, GCESD2

10-16-24

Date

Exhibit E

Exhibit F

Galveston County Emergency Services District #2 Budget Amendment Request Form

Department Entity Name: ESD Date: 9.18.24

Explanation: Decrease Legal Fees \$5,000; Professional Fees \$24,520; CB Electric \$5,000;

Increase Software Services \$1,200; Payroll Taxes \$2,500; Retirement \$4,000; Conferences \$250; Accountant \$4,500;

CB Sewer/Water/Garbage \$3,400; Bond \$120; Salary \$17,500; Employee Medical Benefits \$1,050.

Previous Notice date provided to ESD #2: _____

Budget Amendment Request by Name D.Saunders Title District Manager

Does this Budget Amendment Request include any funding outside of the Department/Entity original approved ESD #2 Fiscal Year budget? Yes _____ No X
 If "Yes" please indicate the source and amount:

For Board Use Only
 Budget Amendment #: ESD 001
 Fiscal Year: 2023-24
 Approval Date: _____

	(1) Cost Center Fund Name	(2) Identifying Line Item Number	(3) Start of FY Budget Amount	(4) Budget Amendment Increase	(5) Budget Amendment Decrease	(6) Amount of Outside Funding Added (If Any)	(7) Amended Budget Line Item Amount	(8) Updated/ Changed Date
A.)	Legal Fees	2200	27,000		5,000		23,000	10.15.24
B.)	Professional Fees	2210	65,000		24,520		40,480	10.15.24
C.)	CB Electric	2830	19,500		5,000		14,500	10.15.24
D.)	Software Services	2110	9,650	1,200			10,850	10.15.24
E.)	Payroll Taxes	2610	14,000	2,500			16,500	10.15.24
F.)	Accountant	2010	15,000	4,500			19,500	10.15.24
G.)	Conferences	2710	3500	250			3,750	10.15.24

II.)	CB Sewer/Water/Garbags	2840	5,600	3,400			9,000	10.1524
I.)	Retirement	2660	10,000	4,000			14,000	10.1524
J.)	Bond	2450	400	120			520	10.1524
K.)	Salary	2630	178,500	17,500			196,000	10.1524
L.)	Employee Medical/Benefits	2650	9,200	1,050			10,250	10.1524

Column Explanation

1. **Cost Center Name-** Within each budget those bold line item names
2. **Identifying Line Item Number-** Individual line item number on each row of ESD #2 approved FY budget
3. **Current FY Budget -** Line item amount authorized by the ESD #2 Board
4. **Budget Amendment Increase/Decrease-** Amount the "Source" line item is to be reduced; and the "Final" line item is to be increased
5. **Amount of Outside Funding Added-** Funding to be added to the Department/Entity budget not internally available- Funding provided by an outside source
6. **Amended Budget Line Item Amount-** Requested amended line item amount if amendment request is approved for both the "source" and "final" line items

Galveston County Emergency Services District #2 Budget Amendment Request Form

Department Entity Name: Capital Date: 10.16.24

Explanation: Decrease New Ambulance & Remounts \$71,794.52

Increase Fire Apparatus/Equipment \$28,494.52; Boat \$2,500; EMS Equipment \$40,800.

Previous Notice date provided to ESD #2: _____

Budget Amendment Request by Name D.Saunders Title District Manager

Does this Budget Amendment Request include any funding outside of the Department/Entity original approved ESD #2 Fiscal Year budget? Yes _____ No X
If "Yes" please indicate the source and amount:

(1)	(2)	(3)	(4)	(5)	(6)	(7)	(8)
Cost Center Fund Name	Identifying Line Item Number	Start of FY Budget Amount	Budget Amendment Increase	Budget Amendment Decrease	Amount of Outside Funding Added (If Any)	Amended Budget Line Item Amount	Updated/ Changed Date
A.) Fire Apparatus/Equipment (Rescue/Medical)	5010	147,005.48	28,494.52			175,500	10.16.24
B.) Boat	5030	4,500	2,500			7,000	10.16.24
C.) EMS Equipment	5050	0	40,800			40,800	10.16.24
D.) New Ambulance & Remount	5060	535,000		71,794.52		463,205.48	10.16.24
E.)							
F.)							
G.)							

For Board Use Only
Budget Amendment #: <u>Capital 001</u>
Fiscal Year: <u>2023-24</u>
Approval Date: _____

--	--	--	--	--	--	--	--	--

Column Explanation

1. **Cost Center Name-** Within each budget those bold line item names
2. **Identifying Line Item Number-** Individual line item number on each row of ESD #2 approved FY budget
3. **Current FY Budget -** Line item amount authorized by the ESD #2 Board
4. **Budget Amendment Increase/Decrease-** Amount the "Source" line item is to be reduced; and the "Final" line item is to be increased
5. **Amount of Outside Funding Added-** Funding to be added to the Department/Entity budget not internally available- Funding provided by an outside source
6. **Amended Budget Line Item Amount-** Requested amended line item amount if amendment request is approved for both the "source" and "final" line items

Galveston County Emergency Services District #2 Budget Amendment Request Form

Department Entity Name: EMS Date: 10.16.24

For Board Use Only

Budget Amendment #: EMS 001
 Fiscal Year: 2023-24
 Approval Date: _____

Explanation: Decrease Software Services \$4,000; Medical Supplies \$45,000; Retirement \$145,000; Employee Medical Benefits \$40,000.

Increase Office Equipment \$3,500; Insurance Auto/Boat \$9,200; Insurance Workers Comp \$6,000; Travel \$200; EMS Equipment \$8,500; Fuel \$4,000; Oxygen \$3,000; Background Checks \$500; Uniforms \$11,000; Port B Rent \$150; Payroll Tax Expense \$7,000; Salary and Hourly Employees \$242,000.

Previous Notice date provided to ESD #2: _____

Budget Amendment Request by Name D.Saunders Title District Manager

Does this Budget Amendment Request include any funding outside of the Department/Entity original approved ESD #2 Fiscal Year budget? Yes No

If "Yes" please indicate the source and amount: Use of Reserves \$50,000

	(1) Cost Center Fund Name	(2) Identifying Line Item Number	(3) Start of FY Budget Amount	(4) Budget Amendment Increase	(5) Budget Amendment Decrease	(6) Amount of Outside Funding Added (if Any)	(7) Amended Budget Line Item Amount	(8) Updated/ Changed Date
A.)	Software Services	42110	16,000		4,000		12,000	10.16.24
B.)	Medical Supplies	42330	90,000		45,000		45,000	10.16.24
C.)	Retirement	42660	275,000		145,000		130,000	10.16.24
D.)	Employee Medical Benefits	42650	190,000		40,000		150,000	10.16.24
E.)	Telephone & Comm.	42820	13,000		5,000		8,000	10.16.24
F.)	Vehicle Maint. & Repair	44900	62,000		3,400		58,600	10.16.24
G.)	Good of the Department	42740	2,500	500			2,500	10.16.24

H.)	Office Equipment	42320	5,000	350			5,350	10.16.24
I.)	Insurance Auto/Boat	42430	45,000	9,200			54,200	10.16.24
J.)	Insurance Workers Comp	42440	45,000	6,000			51,000	10.16.24
K.)	Travel	42500	1,000	200			1,200	10.16.24
L.)	EMS Small Equipment	44000	23,000	8,500			31,500	10.16.24
M.)	Fuel	44200	28,000	4,000			32,000	10.16.24
N.)	Oxygen	44210	4,500	3,000			7,500	10.16.24
O.)	Background Checks	44610	1,000	500			1,500	10.16.24
P.)	Uniforms	44800	12,500	11,000			23,500	10.16.24
Q.)	Port B – Rent	46010	13,800	150			13,950	10.16.24
R.)	Payroll Tax Expense	42610	125,000	7,000			132,000	10.16.24
S.)	Salary & Hourly Employees	42630	1,620,000	242,000			1,862,000	10.16.24
T.)	<i>Use of Reserves</i>					50,000		10.16.24

Column Explanation

1. **Cost Center Name**- Within each budget those **bold** line item names
2. **Identifying Line Item Number**- Individual line item number on each row of ESD #2 approved FY budget
3. **Current FY Budget** - Line item amount authorized by the ESD #2 Board
4. **Budget Amendment Increase/Decrease**- Amount the "Source" line item is to be reduced; and the "Final" line item is to be increased
5. **Amount of Outside Funding Added**- Funding to be added to the Department/Entity budget not internally available- Funding provided by an outside source
6. **Amended Budget Line Item Amount**- Requested amended line item amount if amendment request is approved for both the "source" and "final" line items

**Galveston County Emergency Services District #2
Budget Amendment Request Form**

DS
10-8-24

Department Entity Name: High Island Volunteer Fire Rescue Date: 10/04/2024

Explanation: Reallocation of monies from existing line items to cover deficit line items from 2021-2022 budget

Expected fuel usage increase, pull moneys from Electrical Line Item 2830 and placed in Fuel Line Item 4200 to cover increased cost.

For ESD #2 Use Only Budget Amendment #: <u>HI-002</u> Fiscal Year: <u>2023-24</u> Approval Date: _____

Previous Notice date provided to ESD #2: 10/03/2024

Budget Amendment Request Approved by Requesting Department Entity Board Date: (Prior to ESD #2 Board consideration)

Does this Budget Amendment Request include any funding outside of the Department/Entity original approved ESD #2 Fiscal Year budget? Yes No XX _____

If "Yes" please indicate the source and amount:

(1)	(2)	(3)	(4)	(5)	(6)
Cost Center Fund Name	Identifying Line Item Number	Current FY Budget (start of FY)	Budget Amendment Increase/Decrease	Amount of Outside Funding Added (if Any)	Amended Budget Line Item Amount
Budget line item(s) to be reduced					
A.) Fuel	4200	\$4,000	\$165.37 Increase		\$4,165.37
B.) electricity	2830	\$6,500	\$165.37 Decrease		\$6,334.63
C.)					
D.)					
E.)					

Exhibit G



QUOTE-2831284
8-APX6000

Billing Address:
GALVESTON COUNTY ESD #2
930 NOBLE CARL DR
GALVESTON, TX 77650
US

Shipping Address:
GALVESTON COUNTY ESD #2
930 NOBLE CARL DR
GALVESTON, TX 77650
US

Quote Date:10/04/2024
Expiration Date:12/03/2024
Quote Created By:
Mike Wise
mike.wise@bearcom.com
409.842.1776

End Customer:
GALVESTON COUNTY ESD #2
Chris Reviere
CREVIERE@GCESD2.ORG
409-351-9428

Line #	Item Number	Description	Qty	Contract Price	Sale Price	Ext. Sale Price
	APX™ 6000 Series	APX6000				
1	H98UCF9PW6BN	APX6000 700/800 MODEL 2.5 PORTABLE	8	\$4,250.58	\$4,250.58	\$34,004.64
1a	QA01648AA	ADD: HW KEY SUPPLEMENTAL DATA	8			
1b	G996AU	ADD: PROGRAMMING OVER P25 (OTAP)	8			
1c	QA01767AT	ADD: P25 LINK LAYER AUTHENTICATION	8			
1d	Q667BB	ADD: ADP ONLY (NON-P25 CAP COMPLIANT) (US ONLY)	8			
1e	Q361AR	ADD: P25 9600 BAUD TRUNKING	8			
1f	Q58AL	ADD: 3Y ESSENTIAL SERVICE	8			
1g	QA00580AC	ADD: TDMA OPERATION	8			
1h	H122BR	ALT: 1/4 WAVE 7/8 STUBBY (NAR6595)	8			
1i	H38BT	ADD: SMARTZONE OPERATION	8			
1j	QA09113AB	ADD: BASELINE RELEASE SW	8			
1k	Q806BM	ADD: ASTRO DIGITAL CAI OPERATION	8			
2	PMMN4099CL	AUDIO ACCESSORY-REMOTE SPEAKER MICROPHONE,IP68	8	\$106.92	\$106.92	\$855.36



Any sales transaction following Motorola's quote is based on and subject to the terms and conditions of the valid and executed written contract between Customer and Motorola (the "Underlying Agreement") that authorizes Customer to purchase equipment and/or services or license software (collectively "Products"). If no Underlying Agreement exists between Motorola and Customer, then Motorola's Standard Terms of Use and Motorola's Standard Terms and Conditions of Sales and Supply shall govern the purchase of the Products.
Motorola Solutions, Inc.: 500 West Monroe, United States - 60661 - #: 36-1115800

Line #	Item Number	Description	Qty	Contract Price	Sale Price	Ext. Sale Price
		REMOTE SPEAKER MICROPHONE,3.5MM,UL				
Grand Total						\$34,860.00(USD)

Notes:

- 8 APX6000 Standard Radios for EMS

Standard Capacity Batteries, NO Secure.

Quote includes standard remote speaker microphones
NO single unit chargers,

Standard TxWARN Configuration

- Unless otherwise noted, this quote excludes sales tax or other applicable taxes (such as Goods and Services Tax, sales tax, Value Added Tax and other taxes of a similar nature). Any tax the customer is subject to will be added to invoices.



Billing Address:
GALVESTON COUNTY ESD #2
930 NOBLE CARL DR
GALVESTON, TX 77650
US

Shipping Address:
GALVESTON COUNTY ESD #2
930 NOBLE CARL DR
GALVESTON, TX 77650
US

Quote Date:10/09/2024
Expiration Date:12/08/2024
Quote Created By:
Mike Wise
mike.wise@bearcom.com
409.842.1776

End Customer:
GALVESTON COUNTY ESD #2
Chris Reviere
CREVIERE@GCESD2.ORG
409.351-9428

Line #	Item Number	Description	Qty	Contract Price	Sale Price	Ext. Sale Price
1	RMN5070A	DESKTOP MIC (GCAI)	1	\$148.61	\$148.61	\$148.61
2	HLN7042A	CONTROL STATION MOUNT	1	\$62.05	\$62.05	\$62.05
3	HPN4007D	POWER SUPPLY 14V 15A UNI 110/240 VAC US PLUG	1	\$255.74	\$255.74	\$255.74
4	3060665A04	AC LINE CORD 3 WR 110V	1	\$36.43	\$36.43	\$36.43

Grand Total

\$502.83(USD)

Notes:

- The HLN7042 is a Desktop Tray with Speaker
- Unless otherwise noted, this quote excludes sales tax or other applicable taxes (such as Goods and Services Tax, sales tax, Value Added Tax and other taxes of a similar nature). Any tax the customer is subject to will be added to invoices.



Purchase Order Checklist	
Marked as PO/ Contract/ Notice to Proceed on Company Letterhead (PO will not be processed without this)	
PO Number/ Contract Number	
PO Date	
Vendor = Motorola Solutions, Inc.	
Payment (Billing) Terms/ State Contract Number	
Bill-To Name on PO must be equal to the <i>Legal</i> Bill-To Name	
Bill-To Address	
Ship-To Address (If we are shipping to a MR location, it must be documented on PO)	
Ultimate Address (If the Ship-To address is the MR location then the Ultimate Destination address must be documented on PO)	
PO Amount must be equal to or greater than Order Total	
Non-Editable Format (Word/ Excel templates cannot be accepted)	
Bill To Contact Name & Phone # and EMAIL for customer accounts payable dept	
Ship To Contact Name & Phone #	
Tax Exemption Status	
Signatures (As required)	



Quotation

Quotation#:06192024

06/19/2024

Account Number: 222792-ESHIP001

BILL-TO

GALVESTON CO EMERG SVCS DIST 2
PO BOX 1575
CRYSTAL BEACH, TX 77650-1575

Ship Method: >\$150 NO FRT
Payment Terms: NET 30

SHIP-TO

GALVESTON CO EMERG SVCS DIST 2
930 NOBLE CARL DR
CRYSTAL BEACH, TX 77650

Contact Name Ruthann Broussard EMS Supervisor
Phone Number 409 750 2501 cell
Email rbroussard@gcesd2.org

Item	UOM	Description	Qty	Price	Ext.Price	Exp.Date
2146-01200	1/EA	UE Scope VL460 Monitor, Case, and Charger	5	\$ 1,699.19	\$ 8,495.95	12/31/2024
2146-03236	1/EA	MAC 3 Non Hyper Angulated Blade	5	\$ 39.59	\$ 197.95	12/31/2024
2146-03246	1/EA	MAC 4 Non Hyper Angulated Blade	5	\$ 39.59	\$ 197.95	12/31/2024
2146-03001	1/EA	Single Use Blade Size D0 for UESCOPE 2 (VL460)	5	\$ 46.79	\$ 233.95	12/31/2024
2146-03010	1/EA	Single Use Blade Size D1 for UESCOPE 2 (VL460)	5	\$ 46.79	\$ 233.95	12/31/2024
2146-03020	1/EA	Single Use Blade Size D2 for UESCOPE 2 (VL460)	5	\$ 46.79	\$ 233.95	12/31/2024
2146-03030	1/EA	Single Use Blade Size D3 for UESCOPE 2 (VL460)	5	\$ 46.79	\$ 233.95	12/31/2024
2146-03040	1/EA	Single Use Blade Size D4 for UESCOPE 2 (VL460)	5	\$ 46.79	\$ 233.95	12/31/2025
2146-11102	1/EA	UE Intubation Stylet, P1 (Pediatric)	5	\$ 40.32	\$ 201.60	12/31/2024
2146-11101	1/EA	UE Intubation Stylet, P2 (Adult)	5	\$ 25.20	\$ 126.00	12/31/2024
681400	1/EA	Case, Pelican 1400, Orange with Pick N Pluck Foam, 13.37 in L x 11.62 in W x 6 in D	2	\$ 107.67	\$ 215.34	12/31/2024

Quote Total \$ 10,604.54

Craig Gray

Boundtree | Account Manager Texas Gulf Coast Region
5000 Tuttle Crossing Blvd | Dublin, OH 43016
Phone: 832 385 8440 | Fax: 877 349 2173
craig.gray@boundtree.com |



GCESD2 Budget Planning

Quote Number: 10974540

Remit to: Stryker Sales, LLC
21343 NETWORK PLACE
CHICAGO IL 60673-1213
USA

Version: 1

Prepared For: GALVESTON COUNTY ESD 2
Attn:

Rep: Emma Woltjer
Email: emma.woltjer@stryker.com
Phone Number:

Quote Date: 08/21/2024
Expiration Date: 11/19/2024
Contract Start: 08/21/2024
Contract End: 08/20/2025

Delivery Address		Sold To - Shipping		Bill To Account	
Name:	GALVESTON COUNTY ESD 2	Name:	GALVESTON COUNTY ESD 2	Name:	GALVESTON COUNTY ESD 2
Account #:	20068659	Account #:	20068659	Account #:	20068659
Address:	930 NOBLE CARL DR GALVESTON Texas 77550	Address:	930 NOBLE CARL DR GALVESTON Texas 77550	Address:	930 NOBLE CARL DR GALVESTON Texas 77550

Equipment Products:

#	Product	Description	U/M	Qty	Sell Price	Total
1.0	650705550001	6507 POWER PRO 2, HIGH CONFIG	PCE	1	\$33,516.00	\$33,516.00
2.0	650707000002	KIT, ALVARIUM BATTERY, SERVICE	PCE	1	\$1,091.00	\$1,091.00
3.0	650700460301	ASSEMBLY, BATTERY CHARGER	PCE	1	\$1,561.00	\$1,561.00
4.0	625705550002	6257 XPEDITION HIGH CONFIG	PCE	1	\$17,055.00	\$17,055.00
Equipment Total:						\$53,223.00

Trade In Credit:

Product	Description	Qty	Credit Ea.	Total Credit
TR-SPCOT-PPXT	TRADE-IN-STRYKER POWER COT TOWARDS PURCHASE OF POWERPRO XT	2	-\$1,023.10	-\$2,046.20

ProCare Products:

#	Product	Description	Qty	Sell Price	Total
6.1	POWERPRO-PROCARE	Power Pro 2 for 6507 POWER PRO 2, HIGH CONFIG 08/22/2024 - 08/21/2025	1	\$305.00	\$305.00
6.2	XPEDITION-PROCARE	Xpedition Stair Chair for 6257 XPEDITION HIGH CONFIG 08/22/2024 - 08/21/2025	1	\$160.00	\$160.00



GCESD2 Budget Planning

Quote Number: 10974540

Remit to: Stryker Sales, LLC
21343 NETWORK PLACE
CHICAGO IL 60673-1213
USA

Version: 1

Prepared For: GALVESTON COUNTY ESD 2
Attn:

Rep: Emma Woltjer
Email: emma.woltjer@stryker.com
Phone Number:

Quote Date: 08/21/2024

Expiration Date: 11/19/2024

Contract Start: 08/21/2024

Contract End: 08/20/2025

#	Product	Description	Qty	Sell Price	Total
ProCare Total:					\$485.00

Price Totals:

Estimated Sales Tax (0.000%):	\$0.00
Freight/Shipping:	\$738.22
Grand Total:	\$52,380.02

Prices: In effect for 30 days

Terms: Net 30 Days

Terms and Conditions:

Deal Consummation: This is a quote and not a commitment. This quote is subject to final credit, pricing, and documentation approval. Legal documentation must be signed before your equipment can be delivered. Documentation will be provided upon completion of our review process and your selection of a payment schedule. Confidentiality Notice: Recipient will not disclose to any third party the terms of this quote or any other information, including any pricing or discounts, offered to be provided by Stryker to Recipient in connection with this quote, without Stryker's prior written approval, except as may be requested by law or by lawful order of any applicable government agency. A copy of Stryker Medical's terms and conditions can be found at https://techweb.stryker.com/Terms_Conditions/index.html.

Purchase Order Form



Account Manager : Emma Woltjer

Purchase Order Date : 09-17-2024 14:31:00 -0400

Cell Phone :

Expected Delivery Date :

Stryker Quote Number : 10974540

Customer PO Number :

Bill To	Customer # : 20068659
Company Name :	GALVESTON COUNTY ESD 2
Contact or Department :	
Street Address :	930 NOBLE CARL DR
Add'l Address Line :	
City, ST, ZIP :	GALVESTON, TEXAS, 77550
Phone :	

Sold To / End User	Customer # : 20068659
Company Name :	GALVESTON COUNTY ESD 2
Contact or Department :	
Street Address :	930 NOBLE CARL DR
Add'l Address Line :	
City, ST, ZIP :	GALVESTON, TEXAS, 77550
Phone :	

Deliver To	Customer # : 20068659
Company Name :	GALVESTON COUNTY ESD 2
Contact or Department :	
Street Address :	930 NOBLE CARL DR
Add'l Address Line :	
City, ST, ZIP :	GALVESTON, TEXAS, 77550
Phone :	

Authorized Customer Initials

DS

Authorized Customer Initials

DS

Authorized Customer Initials

DS

Description	Total
5025	\$52,380.02

Total : \$52,380.02

Exhibit H

To: Galveston County ESD #2
Doug Saunders – District Manager
dsaunders@gcesd2.org or 409-684-2016 ext. 3

Date: 10/15/2024

From: High Island Fire Dept., Asst. Chief R. Loftin

District Manager,

We would like to formally notify you of our "INTENT TO PURCHASE" in accordance with Section 5.03 (H) of our contract.

- Item/Description (include Manufacturer and Model if possible) (1) 500 Gallon UL 142 Double Wall Skid Tank Per Attached

Drawing: _____

_____ Delta Tank INC. Houston TX

- Justification/Intended purpose explanation.

_____ High Island Fire
would like to purchase a 500 gallon fuel tank for refueling apparatus at the High Island Fire Station

Total cost \$ 2458.50 _____ Is insurance required for purchase NO _____

Dept Representative

Received



Richard Loftin / Asst. Chief

Doug Saunders / District Manger

Email this form to dsaunders@gcesd2.org and retain a received email from the District Manager with signature and date

Richard,

Here you go.... Please carefully review below:

(1) 500 Gallon Single Wall Non-UL 142 Overhead Tank Per Attached Drawing: \$1,572.90 each

(1) 500 Gallon Single Wall Non-UL 142 Farm Skid Tank Per Attached Drawing: \$1,183.35 each

(1) 500 Gallon UL 142 Double Wall Skid Tank Per Attached Drawing: \$2,458.50 each

Thanks,

Kyle

Please note each city/state's rules/regulations could vary. Delta is not advising on what to purchase or install. It is always best to relay the information to the local authorities governing above ground storage tanks for fuel and flammable liquids to ensure you're in compliance. Usually this is your local fire marshal.

NOTE: Quoted price and availability as stated in this email/invoice are subject to change without notice. No holds, order and delivery are confirmed on a first come first serve basis subject to funds received.

Delta Tank, Inc
4141 Pinemont Dr
Houston TX 77018
www.deltatank.com

Office Hours: Mon-Fri 8am to 3pm

Shipping hours: Mon-Fri 8am to 2pm. Closed 11:00am to 12:30pm

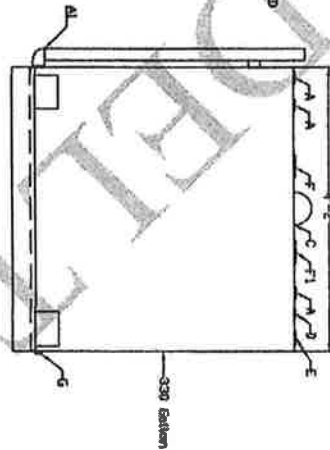
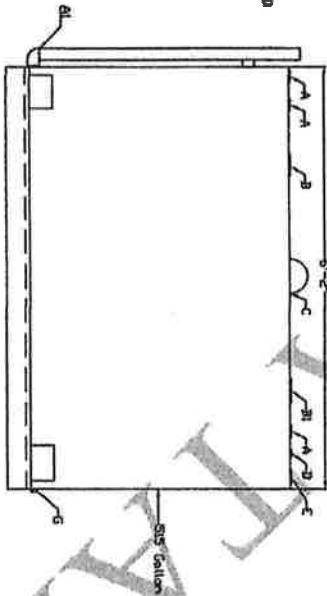
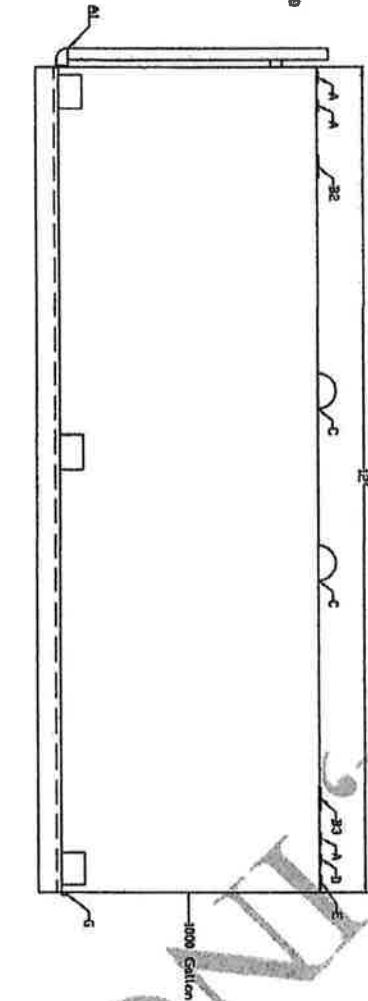
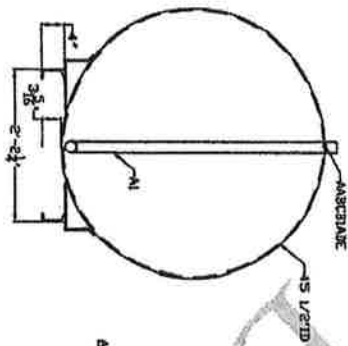
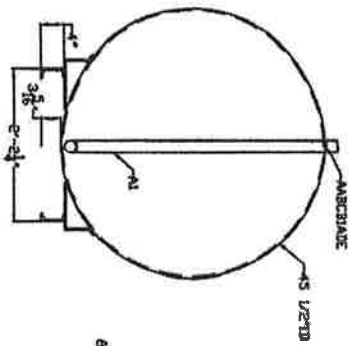
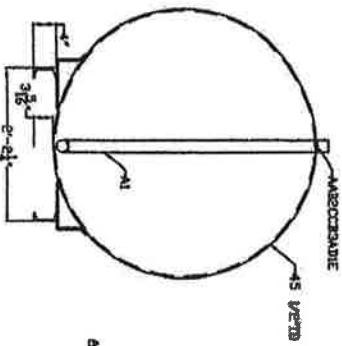

Front View

Elevation View

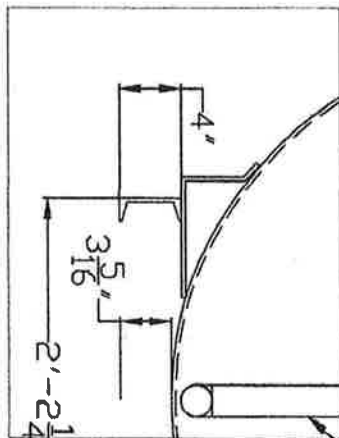

Schedule Df Fittings	
Ref	Qty Description
A	3 2" NPT
A1	1 2" NPT Outer Small Kenkor Pipe
B	1 4" NPT + Bubble EV
B1	1 4" NPT + Durabite EV
B2	1 6" NPT + Bubble EV
B3	1 6" NPT + Durabite EV
C	1 1/2" Lifting Lug
D	1 2" NPT + 1-Vert
E	1 2 1/2" NPT + Fill Cap
F	1 3" NPT + Inside EV
F1	1 3" NPT + Outside EV
G	1 1" NPT Outer Small Drain

General Notes
 Tank Type: Double Wall
 Construction Code: U/L 142
 Estimated Weight: 330 Gallon = 800 lbs
 1000 Gallon = 1900 lbs
 Material: Type III Carbon Steel A516 or A-36 Type
 Tank Thickness: 330/515 Gallon = All 12 Gauge
 1000 Gallon = Inside 10 Gauge
 Outside 12 Gauge
 Structural Support: Angle Iron + Charcol Iron
 Design and Operating Temperature: Ambient Conditions
 Design and Operating Pressure: Atmospheric or 10 psi
 Radiography: N/A
 Corrosion Allowance: N/A
 Internal Coating: Epoxy and water
 External Coating: Red Oxide Primer
 Fittings: 3/8" NPT Threads Optional Pipe Thread
 Internal Seal: Veld N/A
 External Coating: Red Oxide Primer

Additional Notes
 1) Stationary use only. Move/Lift tanks while empty.
 2) All primary tank openings located on top.
 3) All top fittings may be spaced accordingly.
 4) Outside tank is a tight wrap.

Delta Tank, Inc. Houston, TX			
Date	3/23/2019	Size	Standard
Scale	3/8" = 1'-0"	DWG No.	DUAL-5-2
Rev	2	File Name	DUAL-5-2
Designed By	Kyle Long	REV	N/A

Exhibit I



Galveston County Emergency Services District #2

Position Title: Paramedic Supervisor Board Approved 02-24-2021

Reports to: GCESD#2 District Manager

Pay Grade: Full Time FLSA Status: Exempt X Non-Exempt

Pay Step: Hourly

Position Summary

Serves as shift's leader for an assigned shift, in addition to serving as senior crew member on an EMS unit; performs all functions required of a Paramedic in the Galveston County ESD2 – EMS.

Essential Functions

Issues work assignments to line personnel and conducts follow-up inspections. Inspects EMS units to ensure cleanliness, proper stocking of supplies, proper functioning of equipment, compliance with Texas Department of State Health Services (TX-DSHS) and Galveston County ESD2 - EMS criteria. Inspects EMS stations and ground for cleanliness, upkeep and appearance. Inspects personnel for uniform appearance and compliance with policies and procedures. Inspects narcotics and narcotic logs. Conducts in-service training sessions with line personnel. Responds with individual EMS units to observe and critique Paramedic and Medic patient contacts, skills, protocol compliance, and driving skills. Performs other duties as required.

Required Knowledge and Skills

- **Physical Requirements:** Constantly sets; frequently sits, kneels, squats, stands, stoops, twists body, walks, writes by hand and operates emergency vehicle/equipment, carries, drags, holds, pulls and pushes objects weighing up to 200 lbs.(usually with assistance of partner on weights over 100 lbs.), operates PC; infrequently climbs and runs.
- **Knowledge:** Knowledge of all areas of Paramedic training as set out by the TX-DSHS or National Registry and the U.S. Department of Transportation; thorough knowledge of Galveston County ESD2 - EMS policies, procedures and protocols; thorough knowledge of ambulances, communications, and emergency medical equipment; knowledge of supervisory practices and procedures; knowledge of Incident Command System (ICS).
- **Skills/Abilities:** Ability to perform paramedic skills and operate extrication equipment with a high level of effectiveness; ability to operate ambulances and other emergency vehicles in a safe manner, including communications and medical equipment, lights, and sirens; ability to carry out and issue oral and written instructions; ability to establish and maintain effective working relationships with other employees, rescue personnel, other healthcare professionals and the public; ability to supervise personnel on assigned shift; ability to prepare and conduct in-service training programs; ability to supervise subordinate line personnel and actively support management in performance of objectives and attaining goals; ability to perform effective critical-thinking, problem-solving and decision-making skills; ability to collect, process, and analyze information; ability to develop and implement plan of action. Ability to use software

such as, but not limited to; MS-Excel, MS-Words, MS-PowerPoint, internet and other related technology hardware and software.

- **Education/Experience:** Graduation from high school or equivalent, two years or more of college preferred; Emergency Medical Technician-Paramedic certification or Licensed Paramedic by the TX-DSHS; minimum 2 years full-time experience with the Galveston County ESD2 or 4 years with a 911 based EMS system - EMS minimum 2 years related supervisory experience; certified in Basic Trauma Life Support (BTLS) or Pre-Hospital Trauma Life Support (PHTLS) and Advanced Cardiac Life Support (ACLS), Basic Life Support (BLS) Pediatric Education for Pre-hospital Professional (PEPP), Instructor Certification preferred. Advanced training/education in emergency medicine, rescue practices, hazardous materials or related fields preferred.
- **Preferred Qualifications:** Instructor Certification, Associate Degree or 60 college credit hours

Working Conditions

Works inside and outside in all kinds of weather; exposed to persons with unknown illnesses, distressed observers, uncontrolled accident and crime scenes, and the hazards of city traffic, while operating an ambulance under both routine and emergency conditions; works 24-hour shifts. Often required to wear and operate multiple layers of PPE for job duties. Frequently exposed to temperature swings and mechanical, electrical, explosive, radiation fume, dust, chemical and toxic waste hazards. Work Hours: 48-hour work week, additional hours may be required.

Galveston County ESD 2 provides equal employment opportunities (EEO) to all persons regardless of age, color, national origin, citizenship status, physical or mental disability, race, religion, creed, gender, sex, sexual orientation, gender identity and/or expression, genetic information, marital status, status with regard to public assistance, veteran status, or any other characteristic protected by federal, state or local law. Galveston County ESD 2 may consider all related education and/or experience in determining the applicant's minimum qualifications.

All Full-Time employees have the option to receive medical, vision and dental insurance.



Galveston County Emergency Services District #2

Position Title: Emergency Medical Technician – Basic/Advanced/ Paramedic

Board Approved 02-24-2024

Reports to: GCESD#2 District Manager

Pay Grade: Full or Part Time

FLSA Status: Exempt X Non-Exempt

Pay Step: Hourly

Position Summary

Serves as crew member on an EMS unit; responds to emergency and non-emergency calls for service; evaluates scenes and responds to conditions as per policies and protocols; assesses patient and provides medical care on the scene and on route to the hospital; operates response vehicles in emergency and non-emergency traffic modes; delivers patients to hospitals; documents activities, including patient care, via written and electronic media; maintains EMS vehicles and equipment; performs routine maintenance and cleaning at EMS facilities; instructs first responders and the public on emergency care, including CPR; attends continuing education for classes for updates on medical procedures; must be available to work 24-hour shifts unless otherwise requested and must be available on short notice.

Essential Functions

- **Job Functions:** Performs other duties as required. Job description statements are intended to describe the general nature and level of work being performed by employees assigned to this job title. They are not intended to be construed as an exhaustive list of all responsibilities, duties and skills required.

Required Knowledge and Skills

- **Knowledge:** Thorough working knowledge of all EMT-B or EMT-Advanced level and Paramedic objectives as specified by the Texas Department of State Health Services (DSHS) for current certification; thorough working knowledge of the operation of EMS ambulance vehicle; thorough working knowledge of EMS communications and medical equipment; thorough knowledge of EMS medical protocols and medical procedures as well as ACLS and BTLIS standards if applicable.
- **Skills/Abilities:** Ability to read and write; ability to carry out all physical and psycho-motor skills necessary for emergency medical care; ability to operate ambulance safely in both emergency (using lights and siren) and non-emergency modes; ability to remain calm and follow oral and written procedures and instructions clearly and accurately in emergency situations; ability to complete written medical documentation; physical ability to perform difficult task in harsh environments; ability to demonstrate compassion to patients and family; ability to demonstrate good customer relations skills; ability to effectively manage difficult interpersonal situations and conflicts involving patients, family members, bystanders, and other health care or public safety workers; ability to demonstrate effective and positive interpersonal relationship skills with co-workers and supervisors, in both routine and stressful circumstances; ability to correctly apply knowledge of Basic curriculum, medical protocols, and procedures to patient; ability to

effectively manage and provide leadership to first responders and new paramedics to the BEMS system.

- **Physical Requirements:** Constantly sees, hears, stands, sits, walks, stoops, bends, and climbs; frequently pulls, pushes, lifts and carries objects weighing in excess of 100 lbs.; requires physical dexterity and stamina while driving a rescue vehicle in emergency conditions and while performing emergency procedures; often works in uncomfortable positions.

Minimum Requirements

- **Education/Experience:** Graduate from high school or equivalent is required. Must possess current EMT-B or EMT-A -Paramedic certification in good standing with the DSHS or Nationally Registered EMT-B / EMT-I / Paramedic certification required. **Required to obtain EMT-B / EMT-A/ Paramedic certification/licensure from Texas DSHS within 2 years after completion of the probationary period.** Successful completion of ACLS, BTLs/PHTLS, PALS/PEPP or must be completed within the first six (6) months of employment. (2 years of 911 experienced is desired).
- **Other:** Must be able to successfully complete DSHS skills testing at an EMT-B / EMT-A / Paramedic level and job-related abilities test. Required to obtain and maintain full Basic or Advanced level authorization to practice from the EMS Medical Director. Must possess a valid Class C driver's license with a good driving record. Other state valid Driver's license equivalent to Texas Class C with a good driving record will be considered. Texas state law requires within 30 days of residency, you must possess a valid Texas driver's license. Applicant selected for hire will be subject to a background investigation and drug/alcohol screen test.

Working Conditions

Works inside and outside in all kinds of weather; exposed to persons with unknown illnesses, distressed observers, uncontrolled accident and crime scenes, and the hazards of city traffic, while operating an ambulance under both routine and emergency conditions; works 24-hour shifts. Often required to wear and operate multiple layers of PPE for job duties. Frequently exposed to temperature swings and mechanical, electrical, explosive, radiation fume, dust, chemical and toxic waste hazards. Work Hours: 48-hour work week, additional hours may be required.

Galveston County ESD 2 provides equal employment opportunities (EEO) to all persons regardless of age, color, national origin, citizenship status, physical or mental disability, race, religion, creed, gender, sex, sexual orientation, gender identity and/or expression, genetic information, marital status, status with regard to public assistance, veteran status, or any other characteristic protected by federal, state or local law. Galveston County ESD 2 may consider all related education and/or experience in determining the applicant's minimum qualifications and starting salary.

Galveston County ESD 2 provides equal employment opportunities (EEO) to all persons regardless of age, color, national origin, citizenship status, physical or mental disability, race, religion, creed, gender, sex, sexual orientation, gender identity and/or expression, genetic information, marital status, status with regard to public assistance, veteran status, or any other characteristic protected by federal, state or local law. Galveston County ESD 2 may consider all related education and/or experience in determining the applicant's minimum qualifications.

Exhibit J

Agenda# 10 – Continued

MFG: Polaris ATV/VTT

Date of MFG -10/29/2014

Vin# 4XAHR76A8ET36647

Miles – 759

Hours- 2909

Condition – Rust on undercarriage, electrical short will cause battery to drain if not ran or battery tender applied.

History – Unit was donated by Crystal Beach VFD EMS to utilize when only one squad was available now that there are two squads the unit is not being utilized

Recommendation: Offer to Port Bolivar VFD to utilize as a grass unit or Auction on Purple Wave



Exhibit K

BRAND	MODEL	SERIAL #	
Dell	P65F	6G3S142	DM old laptop will be destroyed
Apple	Air2	DMPSPNSPKHGG5D	Commissioner old date 2014
Apple	Air2	DMPSNNCNHGG5D	Commissioner old date 2014
Apple	Air2	DMPSNV2VHGG5D	Commissioner old date 2014
Sentry Safe	tabel top safe	SWF128CS	Dial broke /destroy
Ferno	Stair Chairs	NCEMS tags	Donation / not used or certified
Sho-Me	Light Bar		Donate to HI first responder
Radio Bank	Motorola	WPLN4121BR	No longer compatible with current system

Exhibit L



District Manager Report

October 16th, 2024

- **Supervisors – Establish ESD credit cards with \$1000 limits and District Manager verbal approval prior to use and Valero Gas cards.**
- **Baxter Plant in North Cove, NC was greatly impacted by Hurricane Helene and IV solutions have been rationed for next 60 days. Modifications will be made to streamline a smaller bag when needed.**
 - **EMS staffing**

Currently, there is one Paramedic opening and one Supervisor opening. There are 2 current EMT-A that are in Paramedic school and will complete in December. Based on this, and being in the off-season, the opening will not be filled until January 2025 if needed.

- **Off-Season Staffing**

1 position drops - Supervisor staffs Med 22

2 position drops (Modified) – Paramedic/Supervisor on Squad and units staffed in Port Bolivar and High Island.

CALL VOLUME DATA

Day of Week	0	1	2	3	5	6	7	9	10	11	12	13	14	15	16	17	18	19	20	21	22	23	
Sunday	1		3				1	1			1					1			2	1	3		0.64
Wednesday	1			1	1				11		1					2	1			1			0.86
Thursday	2			1					1	1	1		1	1	2			1	1	1			0.59
Saturday	1	3						1		2	2	1		1	2	3		2	2	2	2	2	1.18
Tuesday			1					2	1	1			2	1	1	1	1	1					0.55
Friday				1	1			1	1			1			1	3	2				3		0.64
Monday						1	1			1	1	1		2	1	1	1						0.45
	0.71	0.43	0.57	0.43	0.29	0.14	0.29	0.71	2.00	0.71	0.86	0.43	0.43	0.71	1.00	1.57	0.71	0.57	0.71	0.71	1.14	0.29	0.70

For November and December 2023

- Future discussion changing the color of the ambulance to red – (Example below)



EMS Calls for Service

60

Zone Breakdown

Zone	
Port Bolivar	17
Crystal Beach	35
High Island	3
Out of District	1
Gilchrist	4
	Total 60

Billing

202409 - September

Runs	Charges	Cash Collection	Cash Per Transport
43	\$115,023	\$53,536	\$1,245.01

Payer Mix Percentage

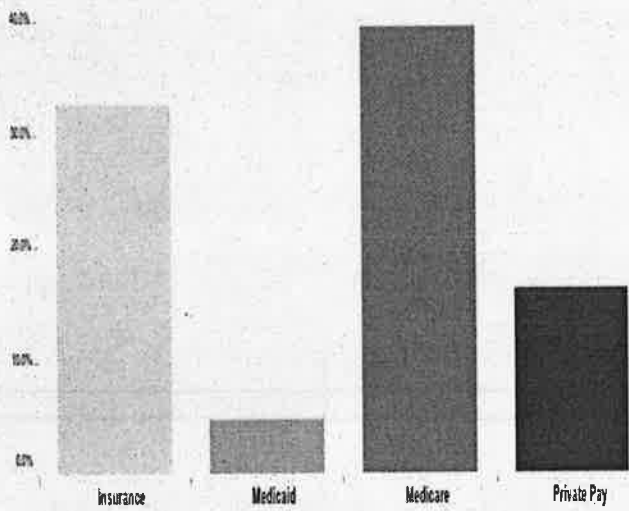

Level Service Percentage

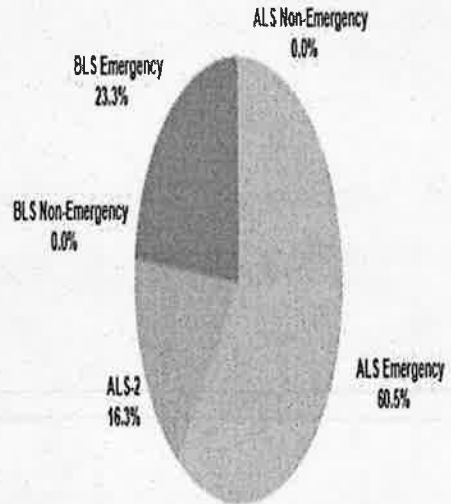

Payer Mix Over Time

Lead Medic for September

ARMSTRONG, CRAIG	12
BLASHILL, DAWN	6
BROUSSARD, ANDREW	5
BROUSSARD, RUTHANN	8
Clark, Rachel	12
DONALDSON, JOSEPH	10
ELLIOTT, MELISSA	5
FIRMIN, TRACEY	2
FOREY, MARK	1
HUFFSTETLER, SEAN	1
HUGHEN, SHEILA	2
ISBELL, REAGEN	12
JACKSON, COLIN	13
Jorgensen, Danielle	9
Marion, Oliver	9
Marsh, Tanner	11
Mather, Joseph	16
McNeil, George	1
Nichols, Ronald	13
Rash, Daniel	8
REVIERE, CHRISTOPHER	24
Rios, Kyle	9
SMITH, AUSTIN	8

VFD Response

ZONE	# INCIDENTS
Central Area - Crystal Beach VFD	27
East End - High Island VFD	4
Gilchrist - Gilchrist	5
West End - Port Bolivar VFD	11

TOTAL: 47

Total Incidents per Personnel for Date Range

Personnel: All Personnel | Sort By: Personnel | Start Date: 09/01/2024 | End Date: 09/30/2024

PERSONNEL	COUNT	PERCENTAGE
<u>Comeaux, Leanne</u>	4	8.51 %
<u>Comeaux, Malcolm M</u>	4	8.51 %
<u>Comeaux, Tommy</u>	3	6.38 %
<u>Duncan, Bruce</u>	2	4.26 %
<u>Forey, Mark</u>	25	53.19 %
<u>Isaacks Jr., Robert L</u>	8	17.02 %
<u>Isaacks, Austin</u>	1	2.13 %
<u>Korpi, Charles W</u>	1	2.13 %
<u>Loftin, April</u>	1	2.13 %
<u>Loftin, Richard</u>	2	4.26 %
<u>Looper, Gerald</u>	3	6.38 %
<u>Manuel, James (Perry)</u>	2	4.26 %
<u>McCurdy, Sharon</u>	1	2.13 %
<u>Mills, David</u>	3	6.38 %
<u>Mills, David D</u>	9	19.15 %
<u>Mills, Jamie</u>	1	2.13 %
<u>Newberry, Gunner</u>	1	2.13 %
<u>OConnor, John (Shannon) S</u>	12	25.53 %
<u>OConnor, Marjorie (Missy) L</u>	5	10.64 %
<u>Riley, Mike</u>	5	10.64 %
<u>Riley, Terrie</u>	4	8.51 %
<u>Roessler, Mike</u>	2	4.26 %
<u>Sayyah, Brandi</u>	1	2.13 %
<u>Stevens, Robin</u>	2	4.26 %
<u>Strimple, Hoss</u>	4	8.51 %
<u>Thompson, Orbin</u>	1	2.13 %
<u>Weeks, William</u>	3	6.38 %
<u>Williams, John</u>	1	2.13 %
<u>Wilson, Loretta</u>	1	2.13 %
<u>Wilson, Timothy</u>	4	8.51 %
Sum of Individual Responses	116	
Total Incidents for Date Range	47	

Exhibit M

Galveston County Emergency Services No. 2

Balance Sheet

As of September 30, 2024

	TOTAL
ASSETS	
Current Assets	
Bank Accounts	
6680 Checking Texas First	183,585.79
6681 Savings - Texas First Bank	2,529.80
6682 - TexStar Capital	132,413.16
6682 - TexStar Emergency	1,133,602.46
6682 - TexStar Savings Account	1,559,717.66
6683 Texas First - Billing Rev. Acc.	151,277.78
Total Bank Accounts	\$3,163,126.65
Accounts Receivable	
1100 Grant Receivable	500.00
Total Accounts Receivable	\$500.00
Other Current Assets	
1110 Property Taxes Receivable	77,919.96
1111 Deferred Portion of Taxes Rec.	-76,128.97
1112 Deferred Ambulance Billings	-44,701.09
1120 Sales Tax Receivable	321,145.13
1125 Other Assets	5,370.62
1126 EMS Receivable	450,257.62
1126.1 Allowance for EMS receivables	-402,309.81
1127 Cash with Agent	23,999.61
1128 Prepaid Expenses	1,500.00
12100 Inventory Asset	260.00
Total Other Current Assets	\$357,913.67
Total Current Assets	\$3,520,939.72
TOTAL ASSETS	\$3,520,939.72
LIABILITIES AND EQUITY	
Liabilities	
Current Liabilities	
Other Current Liabilities	
24000 Payroll Liabilities	38.76
7905 Stryker Lease Issuance	154,700.00
Total Other Current Liabilities	\$154,738.76
Total Current Liabilities	\$154,738.76
Total Liabilities	\$154,738.76
Equity	
32000 General Fund Balance	3,077,804.67
Net Income	288,396.29
Total Equity	\$3,366,200.96
TOTAL LIABILITIES AND EQUITY	\$3,520,939.72

Galveston County Emergency Services No. 2

Budget vs. Actuals: FY_2023_2024 - FY24 P&L

October 2023 - September 2024

	TOTAL			
	ACTUAL	BUDGET	OVER BUDGET	% OF BUDGET
Income				
1000 Property Tax Collections	1,448,994.38	1,370,000.00	78,994.38	105.77 %
1002 Sales Tax Revenue	1,971,885.25	1,500,000.00	471,885.25	131.46 %
1004 Emergency Service Billing	532,422.33	200,000.00	332,422.33	266.21 %
1010 Other Revenue	56,205.94		56,205.94	
1020 Interest Income - Bank	142,758.70	60,000.00	82,758.70	237.93 %
Total Income	\$4,152,266.60	\$3,130,000.00	\$1,022,266.60	132.66 %
GROSS PROFIT	\$4,152,266.60	\$3,130,000.00	\$1,022,266.60	132.66 %
Expenses				
2000 Auditing	10,950.00	12,000.00	-1,050.00	91.25 %
2010 Accountant Fees	19,468.75	15,000.00	4,468.75	129.79 %
2110 Software Services	10,849.54	9,650.00	1,199.54	112.43 %
2200 Legal Fees	22,560.82	27,000.00	-4,439.18	83.56 %
2210 Professional Fees Other	22,941.68	65,000.00	-42,058.32	35.29 %
2320 Office Equipment	1,632.11	2,000.00	-367.89	81.61 %
2420 Insurance-Liability		6,000.00	-6,000.00	
2450 Bond	520.00	400.00	120.00	130.00 %
2500 Travel Expense	1,066.47	3,000.00	-1,933.53	35.55 %
2510 Mileage reimbursement/tolls	12,000.00	12,000.00	0.00	100.00 %
2610 Payroll Taxes	16,346.23	14,000.00	2,346.23	116.76 %
2630 Salary	193,523.35	178,500.00	15,023.35	108.42 %
2650 Employee Medical/Benefits	10,213.79	9,200.00	1,013.79	111.02 %
2660 Retirement	13,991.64	10,000.00	3,991.64	139.92 %
2700 Dues and Subscriptions	360.00	1,900.00	-1,540.00	18.95 %
2710 Conferences	3,617.95	3,500.00	117.95	103.37 %
2820 CB Telephone & Comm	8,516.05	8,800.00	-283.95	96.77 %
2830 CB Electric	14,429.28	19,500.00	-5,070.72	74.00 %
2840 CB Sewer/Water/Garbage	8,990.98	5,600.00	3,390.98	160.55 %
2850 CB Propane	656.19	2,500.00	-1,843.81	26.25 %
2920 Tax Collection Expenses	3,978.56	5,000.00	-1,021.44	79.57 %
2930 County Appraisal Fees (CAD)	9,827.89	10,500.00	-672.11	93.60 %
3010 Crystal Beach VFD	25,939.24	58,250.00	-32,310.76	44.53 %
3020 High Island VFD	74,190.31	84,720.00	-10,529.69	87.57 %
3030 Port Bolivar VFD	36,001.17	71,850.00	-35,848.83	50.11 %
3040 EMS		0.00	0.00	
42110 Software Services	11,810.43	16,000.00	-4,189.57	73.82 %
42210 Professional Fees - Other	2,267.58	5,000.00	-2,732.42	45.35 %
42250 Medical Director Fees	18,000.00	18,000.00	0.00	100.00 %
42310 Office Supplies/Station Supplie	9,893.70	13,000.00	-3,106.30	76.11 %
42320 Office Equipment	5,257.17	5,000.00	257.17	105.14 %
42330 Medical Supplies	44,962.19	90,000.00	-45,037.81	49.96 %
42430 Insurance - Auto/Boat	54,181.66	45,000.00	9,181.66	120.40 %
42440 Insurance Workers Comp	50,835.34	45,000.00	5,835.34	112.97 %

Galveston County Emergency Services No. 2

Budget vs. Actuals: FY_2023_2024 - FY24 P&L

October 2023 - September 2024

	TOTAL			
	ACTUAL	BUDGET	OVER BUDGET	% OF BUDGET
42500 Travel	1,158.74	1,000.00	158.74	115.87 %
42510 Mileage reimbursement/Tolls	209.91	500.00	-290.09	41.98 %
42610 Payroll Tax Expenses	131,598.02	125,000.00	6,598.02	105.28 %
42630 Salary & Hourly Employees	1,860,736.09	1,620,000.00	240,736.09	114.86 %
42640 Payroll Services	6,030.70	9,000.00	-2,969.30	67.01 %
42650 Employee Medical/Benefits	144,189.48	190,000.00	-45,810.52	75.89 %
42660 Retirement	129,978.19	275,000.00	-145,021.81	47.26 %
42720 License & Permits	902.74	3,000.00	-2,097.26	30.09 %
42730 Public Relations		500.00	-500.00	
42740 Good of the Department	2,992.50	2,500.00	492.50	119.70 %
42820 Telephone & Communication	7,848.52	13,000.00	-5,151.48	60.37 %
44000 EMS Small Equipment	31,494.70	23,000.00	8,494.70	136.93 %
44100 Equipment Maint/Repair	7,678.82	10,000.00	-2,321.18	76.79 %
44200 Fuel	30,525.64	28,000.00	2,525.64	109.02 %
44210 Oxygen	7,234.58	4,500.00	2,734.58	160.77 %
44300 Radio Usage	2,495.00	3,000.00	-505.00	83.17 %
44500 Training	25,013.87	25,000.00	13.87	100.06 %
44600 Medical Exams	340.00	750.00	-410.00	45.33 %
44610 Background Checks	1,475.00	1,000.00	475.00	147.50 %
44620 Recruiting		500.00	-500.00	
44800 Uniforms	23,433.70	12,500.00	10,933.70	187.47 %
44900 Vehicle Maint. & Repair	52,275.62	62,000.00	-9,724.38	84.32 %
46010 Port B - Rent	13,950.00	13,800.00	150.00	101.09 %
46020 Port B - Utilities	1,747.00	5,000.00	-3,253.00	34.94 %
Total 3940 EMS	2,680,516.89	2,665,550.00	14,966.89	100.56 %
4050 ESD Fire Equipment/Repair	18,249.06	25,000.00	-6,750.94	73.00 %
5000 Fleet Vehicles	71,007.27	75,000.00	-3,992.73	94.68 %
5010 Fire Apparatus/Equipment	175,254.55	147,005.48	28,249.07	119.22 %
5022 CB Fire Truck Note/Payment	64,937.64	64,937.64	0.00	100.00 %
5030 Boat	6,913.51	4,500.00	2,413.51	153.63 %
5050 EMS Equipment	40,753.04		40,753.04	
5060 New Ambulance&Remounts	283,666.35	535,000.00	-251,333.65	53.02 %
Total Expenses	\$3,863,870.31	\$4,152,863.12	\$-288,992.81	93.04 %
NET OPERATING INCOME	\$288,396.29	\$-1,022,863.12	\$1,311,259.41	-28.20 %
NET INCOME	\$288,396.29	\$-1,022,863.12	\$1,311,259.41	-28.20 %

Galveston County Emergency Services No. 2

6680 Checking Texas First, Period Ending 09/30/2024

RECONCILIATION REPORT

Reconciled on: 10/02/2024

Reconciled by: gosten@gcesd2.org

Any changes made to transactions after this date aren't included in this report.

Summary	USD
Statement beginning balance	334,102.84
Checks and payments cleared (56)	-336,824.50
Deposits and other credits cleared (6)	202,309.82
Statement ending balance	199,588.16
Uncleared transactions as of 09/30/2024	-106,184.66
Register balance as of 09/30/2024	93,403.50

Details

Checks and payments cleared (56)

DATE	TYPE	REF NO.	PAYEE	AMOUNT (USD)
08/21/2024	Check	3995	David Mills	-157.50
08/21/2024	Check	3963	GCM, The Big Store	-17.41
08/21/2024	Check	3964	GCM, The Big Store	-223.91
08/21/2024	Check	3978	Deluxe	-213.42
08/21/2024	Check	3990	Doug Saunders	-115.11
08/21/2024	Check	3991	Threadbearer	-9,971.64
09/03/2024	Expense			-169.00
09/03/2024	Expense			-1,923.81
09/03/2024	Expense			-651.17
09/05/2024	Expense			-1,009.12
09/06/2024	Expense			-53.01
09/10/2024	Expense		Galveston County Auditor	-180.60
09/10/2024	Expense		Galveston County Auditor	-277.64
09/11/2024	Expense			-1,285.86
09/12/2024	Expense			-522.61
09/12/2024	Expense			-192.00
09/12/2024	Expense			-1,010.80
09/13/2024	Journal	MLV 08-55		-73,207.20
09/13/2024	Journal	MLV 08-55		-27,575.75
09/16/2024	Expense			-1,736.13
09/16/2024	Expense		Texas Department of State He...	-44,133.50
09/18/2024	Check	4021	FedEx Office	-61.39
09/18/2024	Check	4005	United Data Technologies, Inc.	-330.00
09/18/2024	Check	4006	ESO - Firehouse Software	-1,539.85
09/18/2024	Check	4009	410 Medical, Inc.	-2,610.00
09/18/2024	Check	4010	Herrera's Emergency Lighting	-286.00
09/18/2024	Check	4011	Stericycle	-224.25
09/18/2024	Check	4012	Sparklets & Sierra Springs	-95.42
09/18/2024	Check	4014	Joshua C. Heinz	-1,000.00
09/18/2024	Check	4015	Visa	-2,214.12
09/18/2024	Check	4016	Crystal Beach VFD	-7,524.37
09/18/2024	Check	4017	Port Bolivar VFD	-6,217.34
09/18/2024	Check	4018	High Island VFD	-17,012.28
09/18/2024	Check	4019	Visa	-6,049.03
09/18/2024	Check	4022	Christopher's Speedy Lube	-113.00
09/18/2024	Check	4023	Southern Tire Mart	-419.40
09/18/2024	Check	4024	TNT Wrecker Service	-408.50
09/18/2024	Check	4025	Kyle Rios	-97.43
09/18/2024	Check	4028	Georgia E Osten	-174.07
09/18/2024	Check	4027	Doug Saunders	-280.98
09/18/2024	Check	4031	Benckenstein & Oxford	-1,750.00
09/18/2024	Check	4032	ESO - Firehouse Software	-395.00

DATE	TYPE	REF NO.	PAYEE	AMOUNT (USD)
09/18/2024	Check	4033	Bound Tree Medical, LLC	-4,471.11
09/18/2024	Check	4034	Coastal Welding	-735.70
09/18/2024	Check	4035	O'Reilly Automotive, Inc.	-345.50
09/18/2024	Check	4036	Galveston County Auditor	-6,336.10
09/18/2024	Check	4037	Vidal Accounting, PLLC	-2,555.00
09/20/2024	Expense			-263.02
09/24/2024	Expense		Undine	-111.10
09/25/2024	Expense			-66,361.36
09/25/2024	Expense			-1,590.00
09/26/2024	Expense			-24,325.24
09/26/2024	Expense			-1,010.80
09/27/2024	Expense			-175.00
09/30/2024	Expense			-89.00
09/30/2024	Expense			-15,025.95
Total				-336,824.50

Deposits and other credits cleared (6)

DATE	TYPE	REF NO.	PAYEE	AMOUNT (USD)
09/04/2024	Deposit			3,152.81
09/05/2024	Deposit			886.32
09/11/2024	Deposit			1,705.43
09/13/2024	Deposit			193,550.57
09/18/2024	Deposit			2,629.17
09/25/2024	Deposit			385.52
Total				202,309.82

Additional Information

Uncleared checks and payments as of 09/30/2024

DATE	TYPE	REF NO.	PAYEE	AMOUNT (USD)
06/24/2024	Journal	Audit-14		-973.88
07/17/2024	Check		Oliver Marion	-3,327.78
08/20/2024	Check	4004	Crescent Electric	-1,389.63
09/18/2024	Check	4028	Sean Huffstetter	-77.94
09/18/2024	Check	4030	GCM, The Big Store	-270.15
09/18/2024	Check	4013	Christopher Reviere	-32.38
09/18/2024	Check	4008	Ron Nichols	-59.52
09/18/2024	Check	4007	Memorial Hermann Life Flight	-9,660.00
09/18/2024	Check	4020	Austin Roche	-211.09
09/27/2024	Journal	MLV 08-56		-66,106.35
09/27/2024	Journal	MLV 08-56		-24,075.94
Total				-106,184.66

Uncleared deposits and other credits as of 09/30/2024

DATE	TYPE	REF NO.	PAYEE	AMOUNT (USD)
07/17/2024	Check	3944	Reagen Isbell	0.00
07/17/2024	Check	3938	Douglas Crouch	0.00
08/21/2024	Check	3996	Kyrish Truck Centers	0.00
Total				0.00